



AI Computing Platform

11D2E2

Datasheet



File Version V1.1

Data 2026-01-19

Copyright by Beijing Plink-AI Technology Co., LTD.2023.All rights reserved.

No part of this document may be reproduced or transmitted in any form or by any means without prior written consent of Plink-AI Technologies Co., Ltd.

Notice

The purchased products, services and features are stipulated by the contract made between Plink-AI and the customer. All or part of the products, services and features described in this document may not be within the purchase scope or the usage scope. Unless otherwise specified in the contract, all statements, information, and recommendations in this document are provided "AS IS" without warranties, guarantees or representations of any kind, either express or implied.

The information in this document is subject to change without notice. Every effort has been made in the preparation of this document to ensure accuracy of the contents, but all statements, information, and recommendations in this document do not constitute a warranty of any kind, express or implied.

Please scan code for more products



Website



Official Accounts



WeChat Channel

Beijing Plink-AI Technology Co., LTD

Web: <http://www.plink-ai.com/>

Add: Room 1108, Jinyu Jiahua Building, Shangdi 3rd Street, Haidian District, Beijing

Tel: +86-010-62962285/400-127-3302

Document History

Version	Date	Description of Change	Hardware Version
V 1.0	2024-10-15	Initial release	V 1.0

Hardware Update History

Versin	Date	Description of Change
V 1.0	2024-10-15	Initial release

Electronic components and circuits are very sensitive to electrostatic discharge, although the company will design the main interface on the board card to do anti-static protection design, but it is difficult to do anti-static safety protection for all components and circuits. Therefore, it is recommended that you take ESD safety measures when handling any circuit board component.



ESD safety measures include but are not limited to the following:

1. Put the card in an ESD bag during transportation or storage. Do not take out the card until installation and deployment.
2. Before touching the board, release the static electricity stored in the body: Wear a grounding wrist strap.
3. Operate circuit boards only in electrostatic discharge safe areas.
4. Avoid moving circuit boards in carpeted areas.
5. Avoid direct contact with electronic components on the board through edge contact.

CONTENTS

Table of Contents

1. Introduction-----	5
2. Specification-----	6
3. External I/O Ports-----	8
4. Dimension Figure-----	10
5. Connector Description-----	11
6. Ordering Information-----	15
7. Recovery Mode-----	15
8. Method of Application-----	16
9. CAN Test-----	16
10.RS232 Test-----	17
11. RS485 Test-----	18
12. Special Instructions-----	18

1 Introduction

11D2E2 AI Computing Platform (referred to as 11D2E2) is compatible with NVIDIA Jetson Orin NX/Orin Nano core modules. It can provide up to 100 TOPS of computing power and has a rich set of external interfaces. The internal interface devices are all wide-temperature models.

11D2E2 can be expanded through the built-in miniPCIe interface, M.2 interface, such as SSD storage card, 4G/5G communication module, various video capture/output cards, AD collection card, multi-serial port card, audio collection/output card, multi-function IO card, etc.

11D2E2 can support up to 4 GMSL/GMSL2 camera module interfaces (GMSL is an optional function, not standard. Please contact our company for GMSL camera models compatible with this product). It reserves the optical isolation IO interface to support 24V DC power input and output. It can be expanded to support POE gigabit network, compatible with industrial automation, vehicle-road coordination and other scene requirements.



2 Specifications

	Feature
Y-C11	Develop carrier board
Module	NVIDIA Jetson Orin NX / Orin Nano Module
Temperature	-20 ~ +65°C
Dimensions (W×D×H)	190.30mm * 163mm * 75.30mm (L/W Not Including I/O ports and mounting holes)
Weight	1603g

Power Supply	Spec
Input Type	DC
Input Voltage	+12 V ~ +24V

Interface	Quantity	Interface	Quantity
USB3.0 Type-A	4	Micro USB	1
RJ45	2	HDMI	1
RS232(DB9)	2	RS485(DB9)	2
CAN	1	SIM Card Slot	1
Opto-Isolated GPI (24V)	4	Opto-Isolated GPO (24V)	4
GMSL	2/4 (GMSL is an optional function, not standard.)		

***RJ45 The POE power supply function is optional. Only external POE power is available. By default, the POE function is not enabled.**

NVIDIA Jetson Series Modules Technical Specifications

Module	Jetson ORIN NX 16GB	Jetson ORIN NX 8GB	Jetson Orin Nano 8GB	Jetson Orin Nano 4GB
AI Performance	157 TOPS	117 TOPS	67 TOPS	34 TOPS
GPU	1024-core NVIDIA Ampere architecture GPU with 32 Tensor Cores		1024-core NVIDIA Ampere architecture GPU with 32 Tensor Cores	512-core NVIDIA Ampere architecture GPU with 16 Tensor Cores
CPU	8-core Arm® Cortex®-A78AE v8.2 64-bit CPU 2MB L2 + 4MB L3	6-core Arm® Cortex®-A78AE v8.2 64-bit CPU 1.5MB L2 + 4MB L3	6-core Arm® Cortex®-A78AE v8.2 64-bit CPU 1.5MB L2 + 4MB L3	
Memory	16GB 128-bit LPDDR5 102.4GB/s	8GB 128-bit LPDDR5 102.4GB/s	8GB 128-bit LPDDR5 68 GB/s	4GB 64-bit LPDDR5 34 GB/s
Storage	Support external NVME			
Video Encode	1x 4K60 (H.265) 3x 4K30 (H.265) 6x 1080p60 (H.265) 12x 1080p30 (H.265)		1080p30 supported by 1-2 CPU cores	
Video Decode	1x 8K30 (H.265) 2x 4K60 (H.265) 4x 4K30 (H.265) 9x 1080p60 (H.265) 18x 1080p30 (H.265)		1x 4K60 (H.265) 2x 4K30 (H.265) 5x 1080p60 (H.265) 11x 1080p30 (H.265)	
Power	10W - 40W		15W - 25W	10W - 25W

3 External I/O Ports



11D2E2 Front Ports

Sign	Function	Sign	Function
SIM	Nano SIM Card Slot	HDMI	Type-A HDMI
Gige1	RJ45 Jack(10/100/1000 BASE-T Ethernet)	Gige2	RJ45 Jack(10/100/1000 BASE-T Ethernet)
REC	Recovery Button	USB	USB 3.0 Type-A
DC12V	Power In (12V ~ 24V)	OTG	Micro USB(OTG)



11D2E2 Back Ports

Sign	Function	Sign	Function
M	GPI Input GND	N	GPO Output GND
I1/I2/I3/I4	Opto-Isolated GPIO Input	O1/O2/O3/O4	Opto-Isolated GPIO output
L	GPO output connected positive electrode (24V)	RS232_0	RS232 Serial Ports
RS232_1	RS232 Serial Ports	RS485_0	RS485 Serial Ports
RS485_1&CAN		RS485 Serial Ports, CAN	
GMSL	GMSL is an optional function, not standard		

4 Dimension Figure

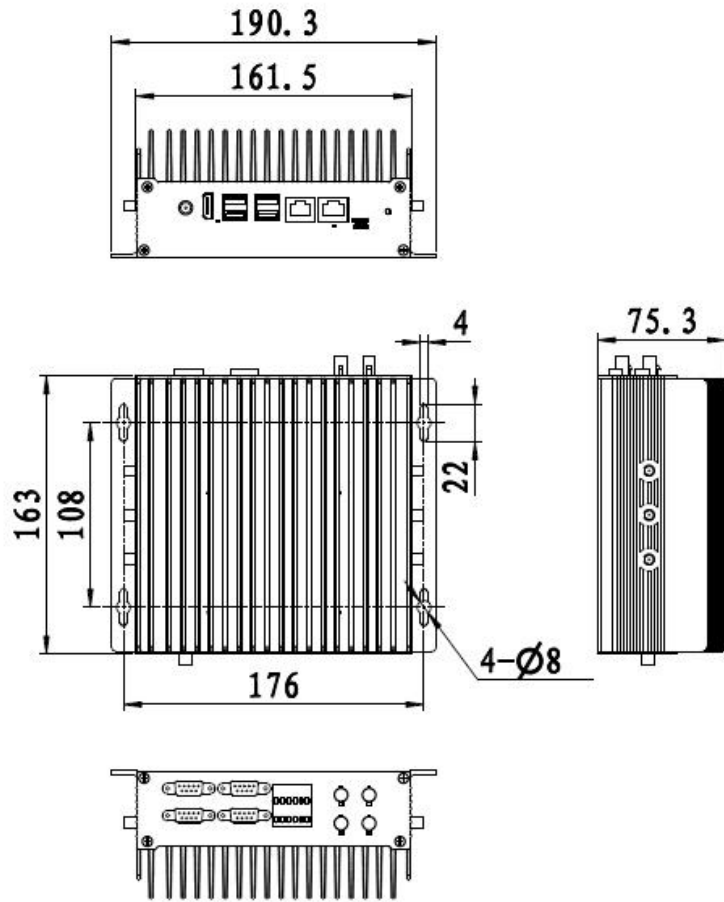

5 Connector Description

GMSL	
Function	Connect to a GMSL camera via a GMSL coaxial cable.
Sign	GMSL
Type /Model	KH-FAK-K508-P
Device Name	<code>/dev/video*</code> (The actual initialized device name after accessing the camera shall prevail. Please refer to more information: https://gitee.com/plink718/plink-gmsl-init/blob/master/README.en.md)
Notice	GMSL is an optional function, not standard.



DB9 Connector (RS232_0/RS232_1)																									
Function	RS232 Serial Ports																								
Sign	RS232_0/RS232_1																								
Type /Model	DB9 Connector																								
Pin definition	<p>Pin 1 : Red frame on the right picture</p> <table border="1"> <thead> <tr> <th>Pin</th> <th>Signal</th> <th>Pin</th> <th>Signal</th> </tr> </thead> <tbody> <tr> <td>1</td> <td>NC</td> <td>2</td> <td>TX_RS232</td> </tr> <tr> <td>3</td> <td>RX_RS232</td> <td>4</td> <td>NC</td> </tr> <tr> <td>5</td> <td>GND</td> <td>6</td> <td>NC</td> </tr> <tr> <td>7</td> <td>NC</td> <td>8</td> <td>NC</td> </tr> <tr> <td>9</td> <td>NC</td> <td>10</td> <td>NC</td> </tr> </tbody> </table>	Pin	Signal	Pin	Signal	1	NC	2	TX_RS232	3	RX_RS232	4	NC	5	GND	6	NC	7	NC	8	NC	9	NC	10	NC
Pin	Signal	Pin	Signal																						
1	NC	2	TX_RS232																						
3	RX_RS232	4	NC																						
5	GND	6	NC																						
7	NC	8	NC																						
9	NC	10	NC																						
Device Name	<table border="1"> <tbody> <tr> <td>RS232_0</td> <td><code>/dev/ttyWCH3</code></td> </tr> <tr> <td>RS232_1</td> <td><code>/dev/ttyWCH2</code></td> </tr> </tbody> </table>	RS232_0	<code>/dev/ttyWCH3</code>	RS232_1	<code>/dev/ttyWCH2</code>																				
RS232_0	<code>/dev/ttyWCH3</code>																								
RS232_1	<code>/dev/ttyWCH2</code>																								

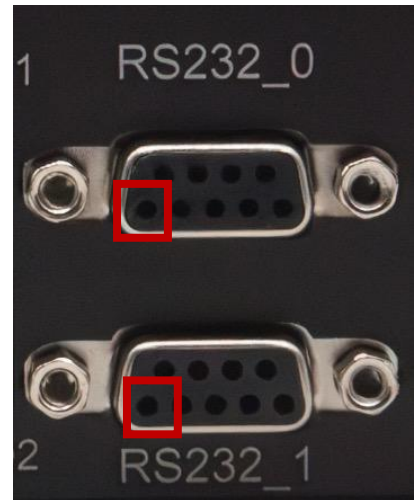

DB9 Connector (RS485_0)																									
Function	RS485 Serial Ports																								
Sign	RS485_0																								
Type /Model	DB9 Connector																								
Pin definition	Pin 1 : Red frame on the right picture																								
	<table border="1"> <thead> <tr> <th>Pin</th> <th>Signal</th> <th>Pin</th> <th>Signal</th> </tr> </thead> <tbody> <tr> <td>1</td> <td>RS485-B</td> <td>2</td> <td>RS485-A</td> </tr> <tr> <td>3</td> <td>NC</td> <td>4</td> <td>NC</td> </tr> <tr> <td>5</td> <td>NC</td> <td>6</td> <td>NC</td> </tr> <tr> <td>7</td> <td>NC</td> <td>8</td> <td>NC</td> </tr> <tr> <td>9</td> <td>NC</td> <td>10</td> <td>NC</td> </tr> </tbody> </table>	Pin	Signal	Pin	Signal	1	RS485-B	2	RS485-A	3	NC	4	NC	5	NC	6	NC	7	NC	8	NC	9	NC	10	NC
	Pin	Signal	Pin	Signal																					
	1	RS485-B	2	RS485-A																					
	3	NC	4	NC																					
	5	NC	6	NC																					
7	NC	8	NC																						
9	NC	10	NC																						
Device Name	/dev/ttyWCH0																								



DB9 Connector (RS485_1&CAN)																									
Function	RS485 Serial Ports, CAN																								
Sign	RS485_1&CAN																								
Type /Model	DB9 Connector																								
Pin definition	Pin 1 : Red frame on the right picture																								
	<table border="1"> <thead> <tr> <th>Pin</th> <th>Signal</th> <th>Pin</th> <th>Signal</th> </tr> </thead> <tbody> <tr> <td>1</td> <td>RS485-B</td> <td>2</td> <td>RS485-A</td> </tr> <tr> <td>3</td> <td>NC</td> <td>4</td> <td>NC</td> </tr> <tr> <td>5</td> <td>NC</td> <td>6</td> <td>NC</td> </tr> <tr> <td>7</td> <td>CAN_H</td> <td>8</td> <td>CAN_L</td> </tr> <tr> <td>9</td> <td>NC</td> <td>10</td> <td>NC</td> </tr> </tbody> </table>	Pin	Signal	Pin	Signal	1	RS485-B	2	RS485-A	3	NC	4	NC	5	NC	6	NC	7	CAN_H	8	CAN_L	9	NC	10	NC
	Pin	Signal	Pin	Signal																					
	1	RS485-B	2	RS485-A																					
	3	NC	4	NC																					
	5	NC	6	NC																					
7	CAN_H	8	CAN_L																						
9	NC	10	NC																						
Device Name	/dev/ttyWCH1																								

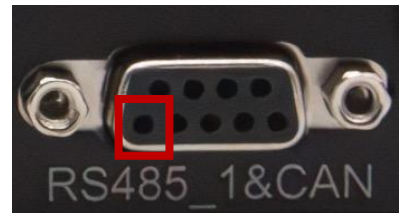

Opto-Isolated GPIO				
Sign	GPIOs			
Pin definition	Pin	Signal	Pin	Signal
	M	GND	M	GND
	I3	GPI3	I4	GPI4
	I1	GPI1	I2	GPI2
	N	GND	L	+24V
	O3	GPO3	O4	GPO4
	O1	GPO1	O2	GPO2
	The sequence of signal pins is shown in the screen print on the right.			
Notice	This interface is optocoupler isolated GPIO, GPI can only be used as input, GPO can only be used as output, does not have the ability of independent input and output, need external 24V power supply; M indicates the GND of the external power supply when GPI is input, N indicates the GND of the external power supply when GPO is output, and L indicates the external 24V power supply when GPO is output.			



Opto-Isolated GPIO	
<p>Instructions</p>	<p>Wire connection steps:</p> <ol style="list-style-type: none"> 1. Press and hold the yellow button in the picture with the screwdriver. 2. Put the wire into the inlet. 3. Release the button. <p>Wire release steps:</p> <ol style="list-style-type: none"> 1. Press and hold the yellow button in the picture with a screwdriver. 2. Pull out the wire from the inlet. 3. Release the button. <p>When using GPI, connect the negative terminal of the external 24V stabilized power supply to M and the positive terminal to the GPI port used. When using the GPO, connect the positive terminal of the external 24V regulated power supply to L and the negative terminal to N, and the GPO can output 24V or lower. Check the GPI input status, or set the GPO output status, please refer to the sample program: https://gitee.com/plink718/11D2E2-io-test</p>
<p>Device Name</p>	<p>/dev/plink-gpios (The current interface needs to refer to the example program to control the mapping file name)</p>

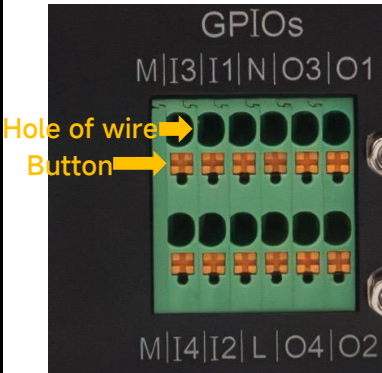

6 Ordering Information

Type	Description
11D2E2	Ai computing platform for NVIDIA® Jetson™ ORIN NX/ORIN Nano series core modules
If you need to add other functional modules, please confirm the plan with the company's sales and technical personnel in advance.	

7 Recovery Mode

Jetson core module can work in normal mode and Recovery mode. In Recovery mode, it can perform file system update, kernel update, Bootloader/UEFI update, BCT update and other operations.

To enter the Recovery mode, perform the following steps:

1. Power off the system.
2. Use a Micro-USB cable to connect the Micro-USB port (OTG) of the 11D2E2 to the Jetson development host USB port.
3. The Jetson development host should be Ubuntu18.04 or Ubuntu20.04 based on X86 architecture.
4. Press the Recovery key (REC) to power the system. Hold down the Recovery key (REC) for more than 3 seconds, and then release the Recovery key (REC).
5. When the system enters Recovery mode, you can perform subsequent operations.

8 Method of Application

- Make sure all external system voltages are off.
- Install necessary external cables. (such as: the display line connected to the HDMI display, the power input line for the system power supply, the USB cable connecting the keyboard and mouse...)
- Connect the power cord to the power supply.
- 11D2E2 The system powers on automatically by default. It can also be set as a switch start, for specific methods, please consult the company's sales and technical personnel.

9 CAN Test

The 11D2E2 is equipped with 1 CAN, You need to connect an external CAN device to test, connect the CAN_H of the device to the CAN_H

The test commands is as follows:

- `sudo apt-get install busybox can-utils`
- `# Writes the specified value to a register`
- `sudo busybox devmem 0x0c303018 w 0xc458`
- `sudo busybox devmem 0x0c303010 w 0xc400`
- `sudo modprobe can #Load the CAN bus subsystem support module`
- `sudo modprobe can_raw #Load the original CAN protocol module.`
- `sudo modprobe mttcan #LoadCAN interface support`
- `sudo ip link set can0 type can bitrate 500000 #Set CAN0 bitrate to 500k bps`
- `sudo ip link set up can0 #Open CAN0`
- `candump can0 #Set CAN0 to receive`
- `cansend can0 1F223344#1122334455667788`
`#Set CAN0 send data`

10 RS232 Test

The 11D2E2 is equipped with two RS232 serial ports as standard, which can be used for self-receiving test of a signal serial port, and connection of two RS232 serial ports for docking test. The command is as follows:

```
# sudo apt-get install cutecom      #install the serial port test tool
# sudo cutecom
```

When testing a single serial port, connect the RX of a single serial port to the TX. When two serial ports are connected, the RX of COM1 is connected to the TX of COM2, and the TX of COM1 is connected to the RX of COM2.

The interface of the serial port test tool cutecom is as follows:

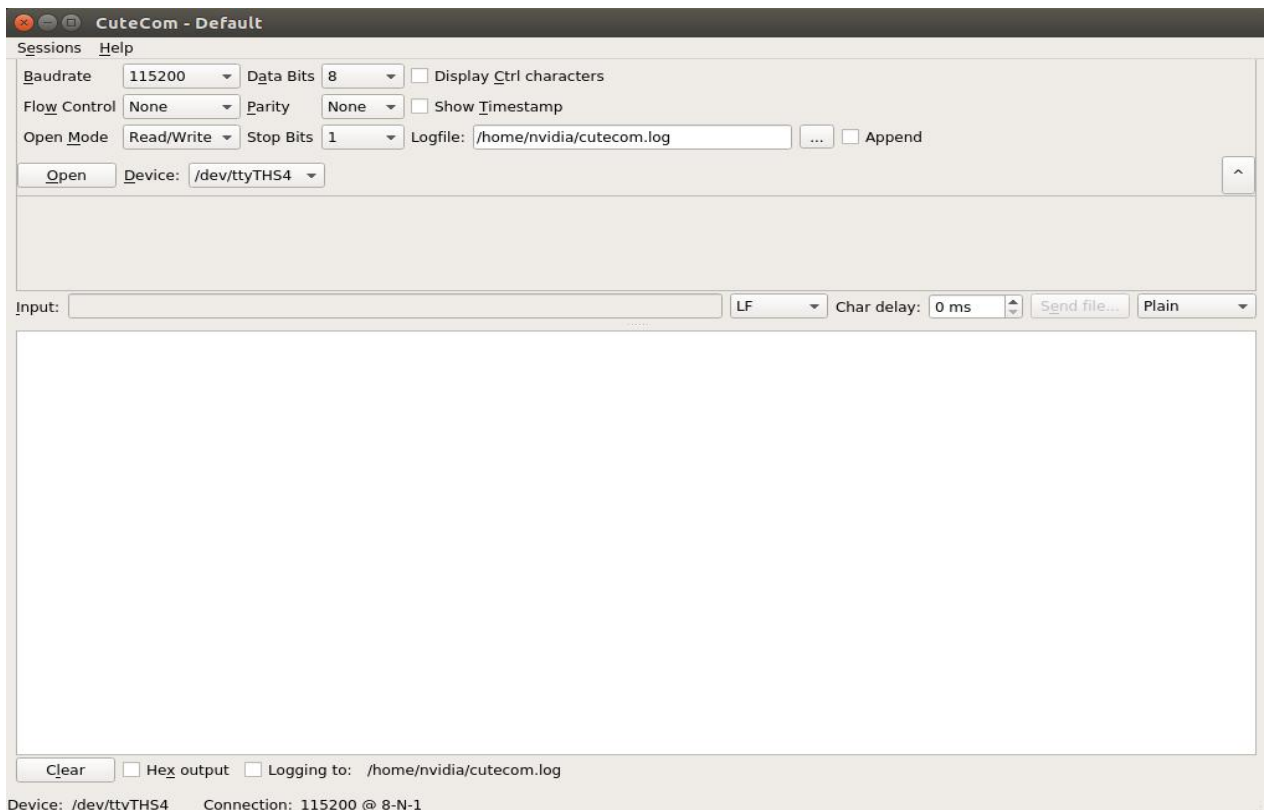

11 RS485 Test

The 11D2E2 is equipped with two RS485 serial ports as standard. You can connect two RS485 serial ports for interconnection test.

Because RS485 needs to be set when it is used, only the example program can be used for testing.

Demo download link: <https://gitee.com/plink718/11D2E2-io-test>

The sample program can also be used to test the RS232 serial port. Please refer to the README in the above link for the sample program usage.

12 Special Instructions

- Initial system user name: nvidia, password: nvidia, no password su. If root permissions are required, use sudo to grant permissions, or use sudo su to access the root user.
- The pre-installed system is pure by default and does not contain Jetpack software. You can use the following command to install the software. Do not replace or modify the default software source before installation:
- `sudo apt-get update`
- `sudo apt-get install nvidia-jetpack`
- It can also be installed over the network using SDKmanager software.
- For more information please refer to: Jetson wiki (plink-ai.com)